

**Shear Stress** ( $\tau$ ) — intensity of internal force tangential (parallel  $\Rightarrow$ ) to the area under question.

**Normal Stress**

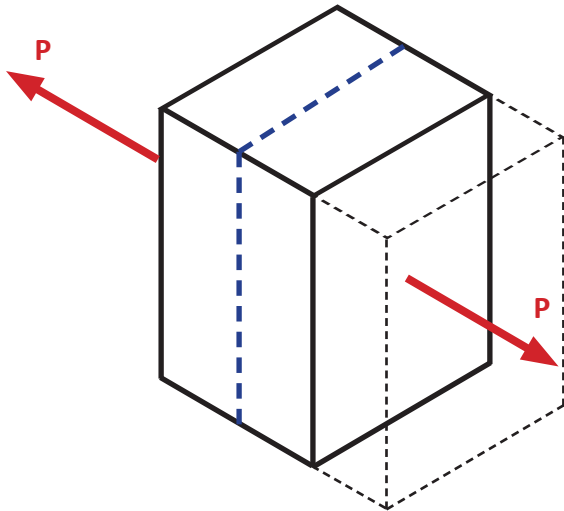

**Normal Stress** =  $\sigma = \frac{P}{A}$   
 Perpendicular to direction of applied force

**Shear Stress**

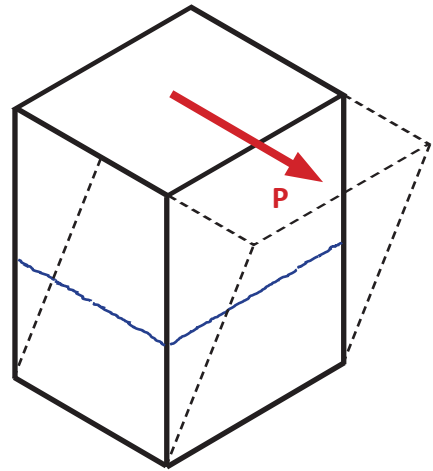

**Shear Stress** =  $\tau = \frac{P}{A}$   
 Parallel to direction of applied force

**Direct Shear**

Consider a block with a protruded part as shown in the figure below.

- A horizontal force  $P$  is applied to the block's protruded part as shown above in (a).
- The force  $P$  tends to shear the part off the block along the shear plane  $abcd$ .
- The body resists the force  $P$  by developing resisting shear stresses in the shear plane.
- The resultant of the shear stresses must be equal to the applied force  $P$ , as shown in (b).
- The shear stress may not be uniformly distributed over the shear area  $A_s$ .

The average shear stress, however, can be calculated from:

$$\tau_{avg} = \frac{P}{A_s} \tag{9-4}$$

where  $\tau_{avg}$  = the average shear stress

$P$  = the internal resisting shear force tangent to the shear plane

$A_s$  = the area of the shear plane

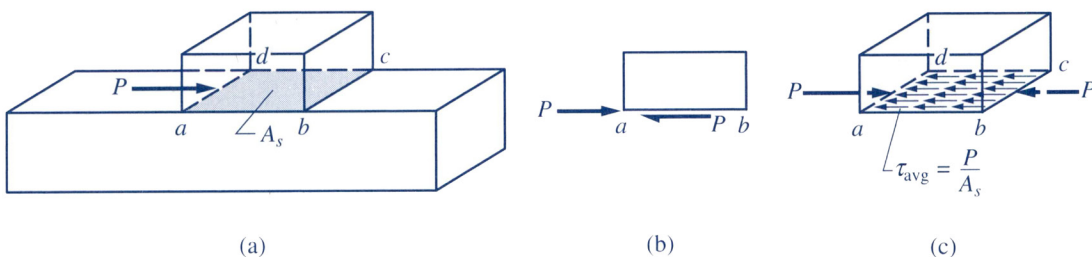

Bearing Stresses

If two bodies are pressed against each other, compressive forces are developed on the area of contact. The pressure caused by these surface loads is called *bearing stress*.

Examples of bearing stress are the soil pressure beneath a pier and the contact pressure between a rivet or bolt and the side of the hole it is in.

If the bearing stress is large enough, it can locally crush the material, which can lead to more serious problems. To reduce bearing stresses, engineers sometimes employ bearing plates, the purpose of which is to distribute the contact forces over a larger area.

**Soil Bearing Capacity**

The Bearing Capacity of Soils is perhaps the most important all all the topics in soil engineering. Bearing Capacity is the capacity of the soil to support the loads applied to the ground. The bearing capacity of soil is the maximum average contact pressure between the foundation and the soil which should not produce shear failure in the soil.

$$\sigma_b = \frac{\text{Load (lb)}}{\text{Area of Footing (ft}^2\text{)}}$$

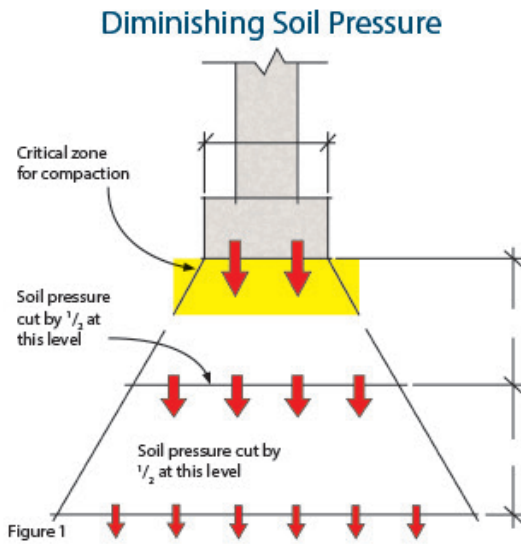

# Bearing Capacity Of

# Different Types Of Soil

Soil Type	Allowable Bearing (lb/ft <sup>2</sup> )	Drainage
BEDROCK	4,000 to 12,000	Poor
GRAVELS	3,000	Good
GRAVELS w/ FINES	3,000	Good
SAND	2,000	Good
SAND w/ FINES	2,000	Good
SILT	1,500	Medium
CLAYS	1,500	Medium
ORGANICS	0 to 400	Poor

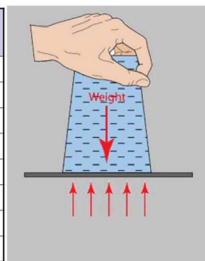
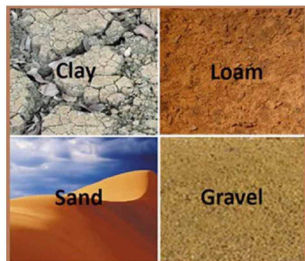



## Clevis Applications

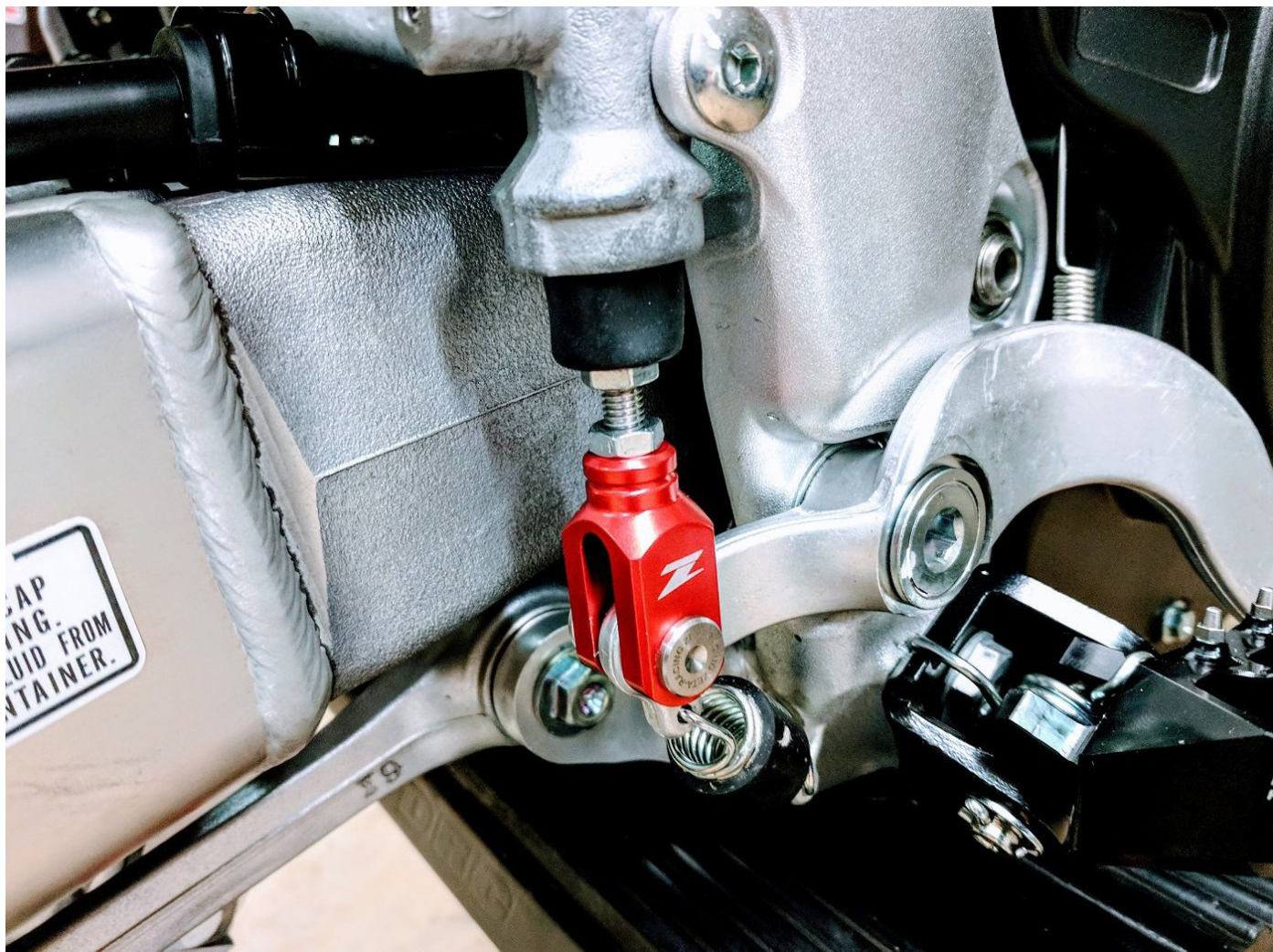
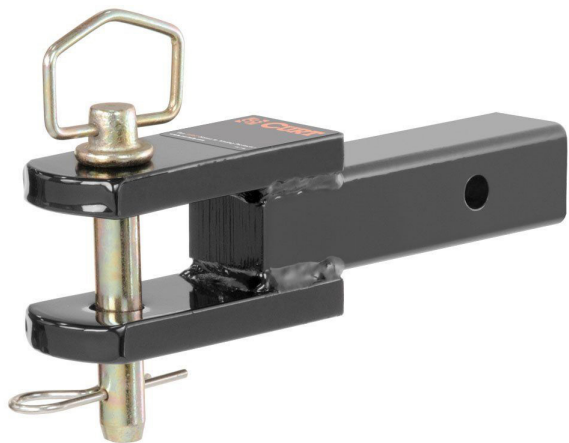

Example - Normal, Shear, Tearout, and Bearing Stresses  
Clevis and Pin

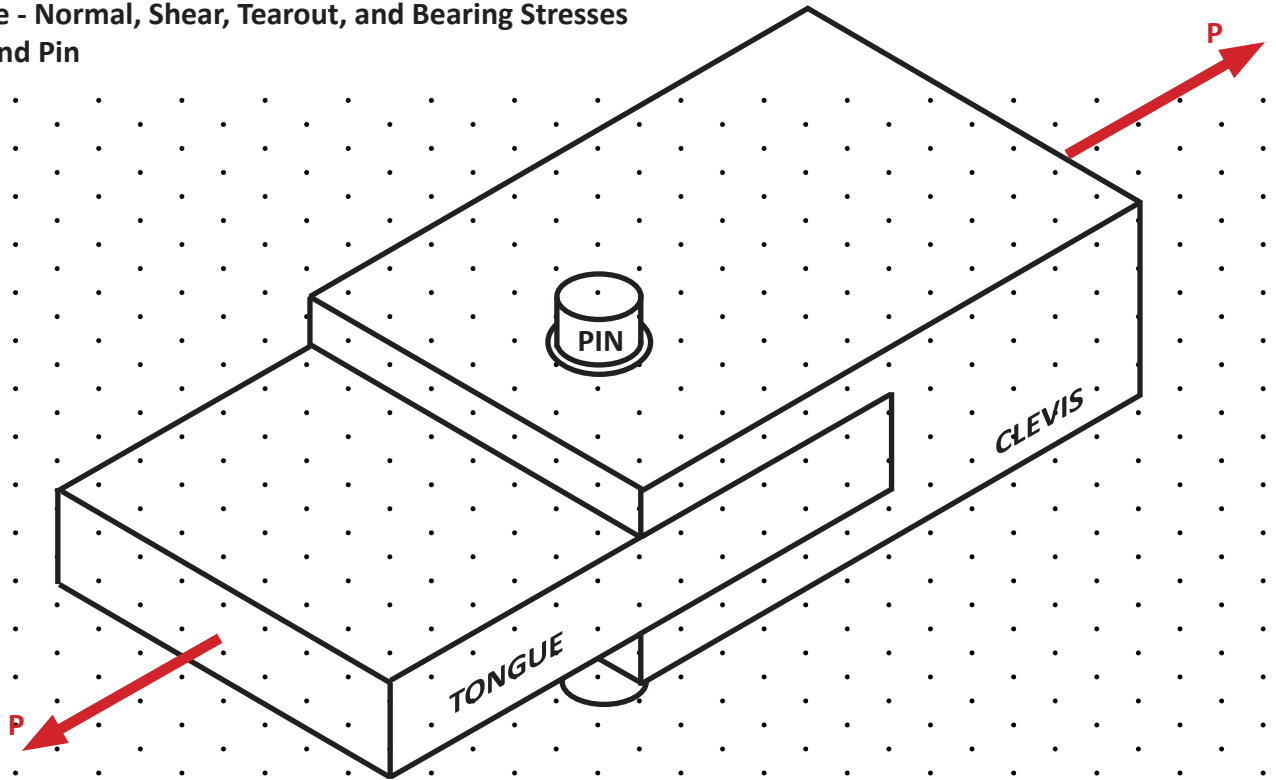

Shearing Stress in Pin

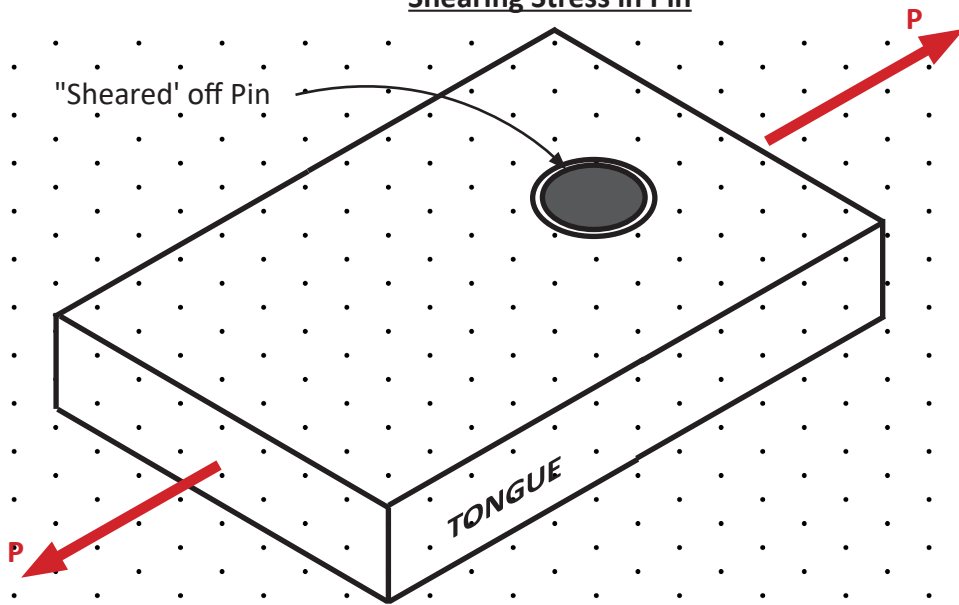

### Normal Stress in Tongue

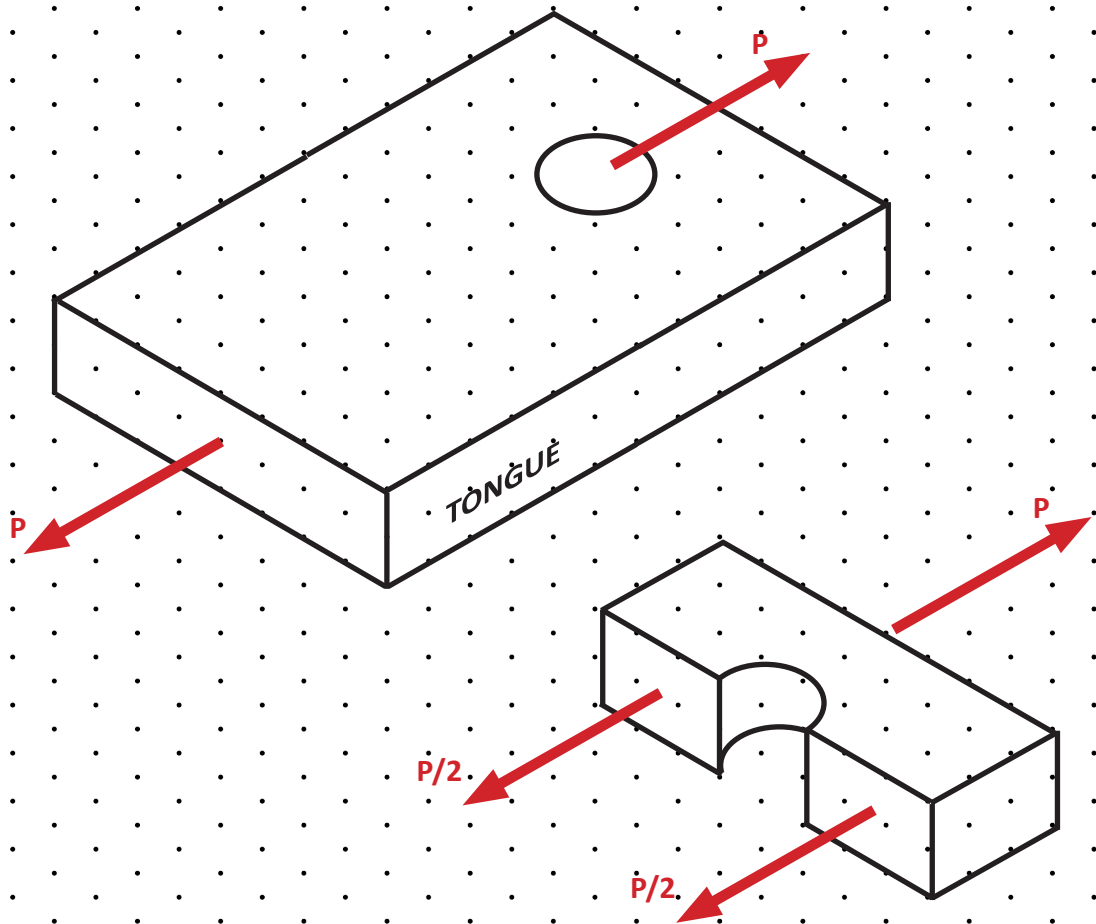

# Tearout Stress

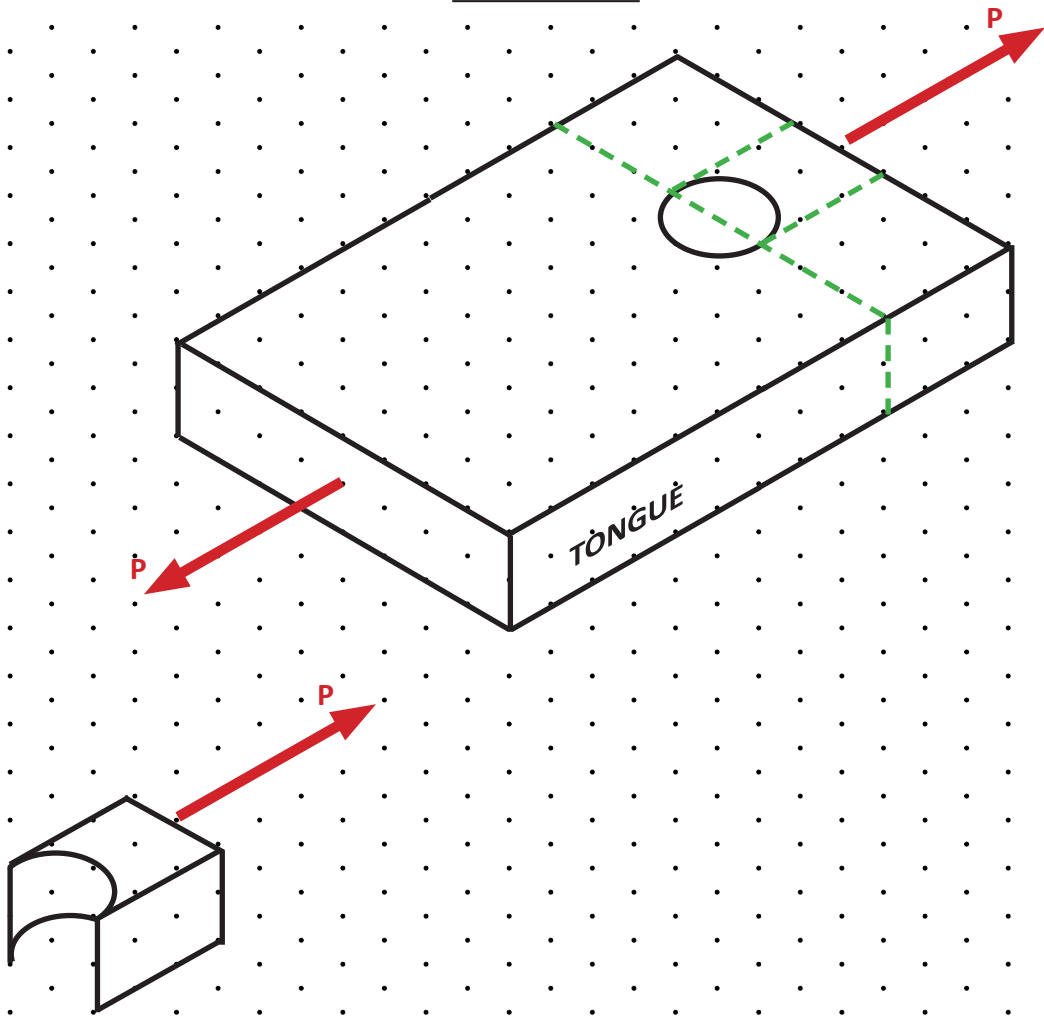

Normal Stress in Clevis

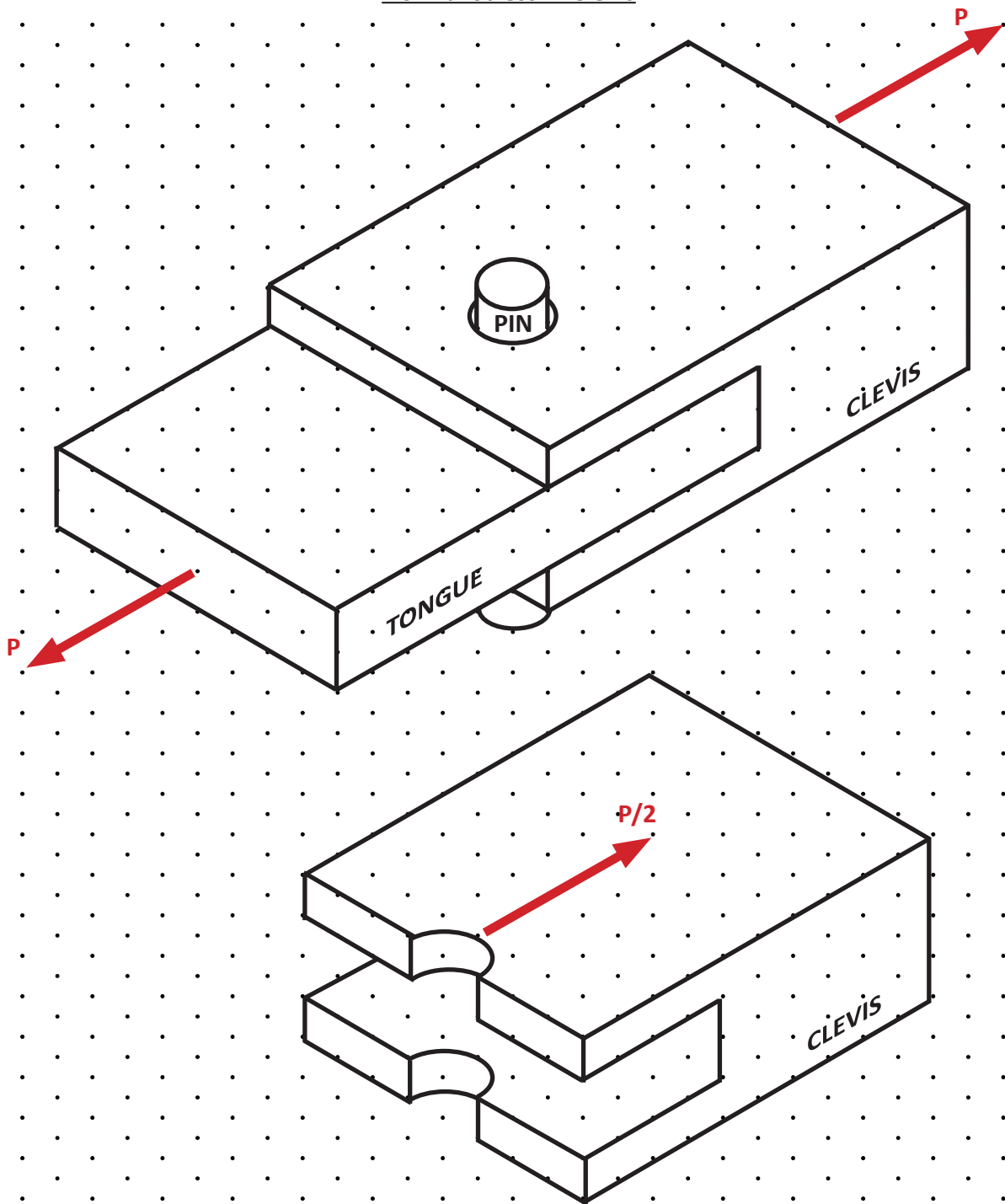

Average Bearing Stress

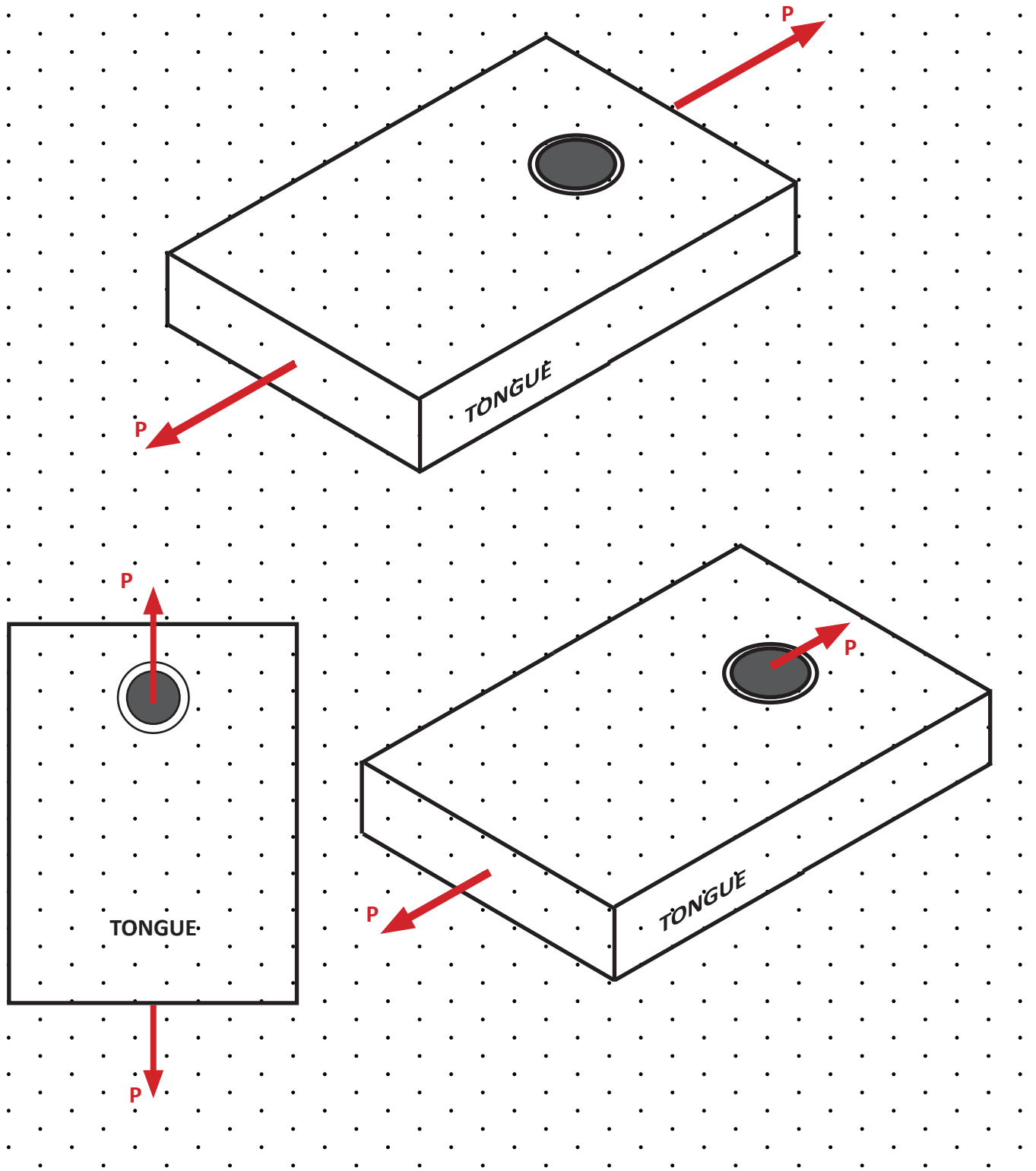



### Lap Joint - Bearing Stress

Consider the lap joint formed by the two plates that are bolted together as shown.

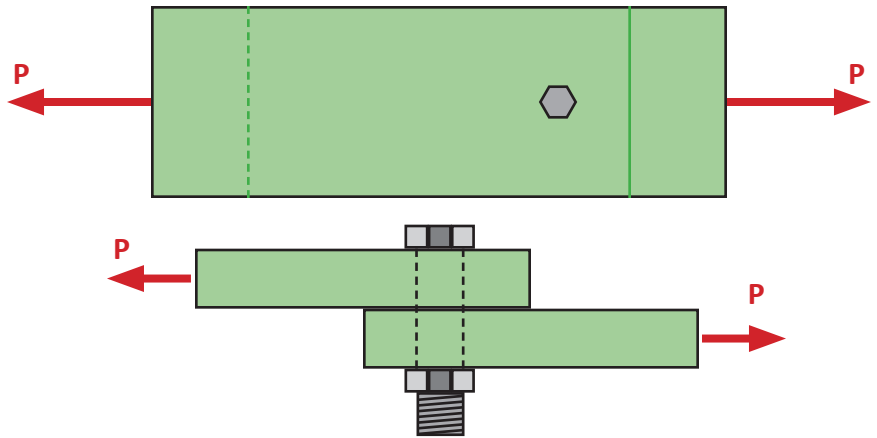

The bearing stress caused by the bolt is not constant; it actually varies from zero at the sides of the hole to a maximum behind the bolt.



This complicated stress distribution is avoided by assuming that the bearing stress  $\sigma_b$  is uniformly distributed over a reduced area.

The reduced area  $A_b$  is taken to be the projected area of the bolt:

$$A_b = td$$

where  $t$  is the thickness of the plate and  $d$  represents the diameter of the bolt.

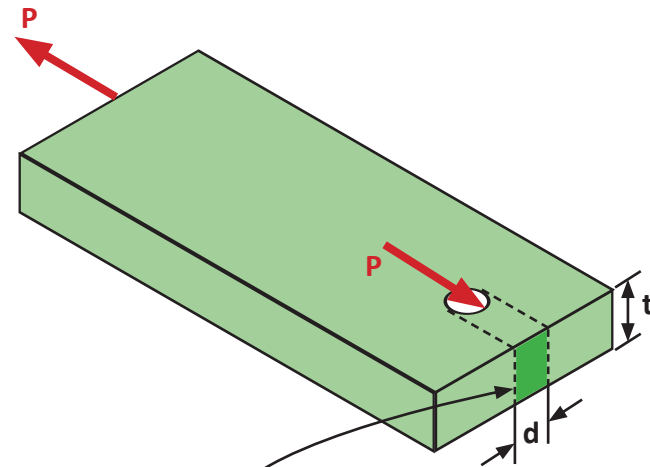

Projected Area of the Bolt

FBD - Top Plate

The Bearing Stress  $P$  is Assumed to be Uniform on Projected Area  $td$

$$\sigma_b = \frac{P}{A_b} = \frac{P}{td}$$

### Lap Joint - Shear Stress

Connects two overlapping tension plates with a rivet (or a bolt).

The average shear stress is

$$\tau_{\text{avg}} = \frac{P}{A_s}$$

where  $A_s$  is the cross-sectional area of the rivet.

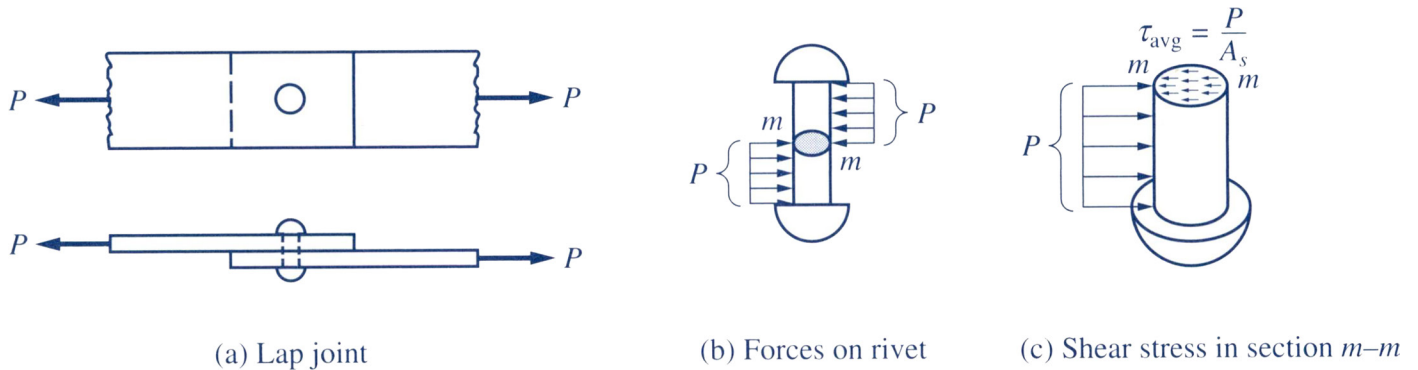

Since the shear stress occurs in only one section of the rivet, it is said to be in single shear. If there are several rivets in the joint, the load is assumed to be shared equally by the rivets.

### The Butt Joint

Connects nonoverlapping tension plates using connecting plates.

Rivet A in the joint is subjected to shear stresses at sections  $m-m$  and  $n-n$ .

Assuming the shear force is shared equally by the two sections, the average shear stress is

$$\tau_{\text{avg}} = \frac{P/2}{A_s} = \frac{P}{2A_s}$$

where  $A_s$  is the cross-sectional area of the rivet.

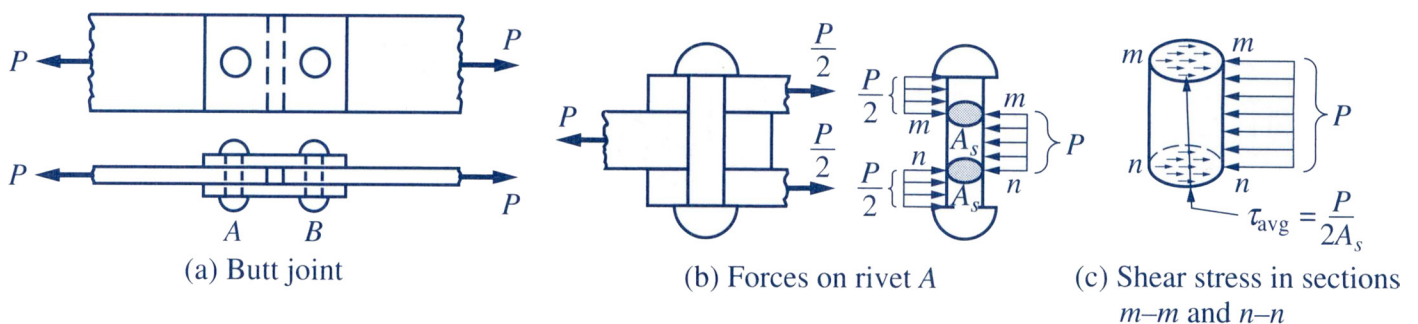

Since the shear stresses occurs in two sections of the rivet, the rivet is said to be in double shear. If there are several rivets on each side of the joint, the load is assumed to be shared equally by the rivets.

**Example**

Consider the block below. The rod is being acted on by the force  $P$  on both sides. The rod is pushing against the block.

Given that the block is 1 in thick and the rod diameter is  $\frac{3}{4}$  in determine the bearing stress between the block and the rod. The force  $P = 50$  lb

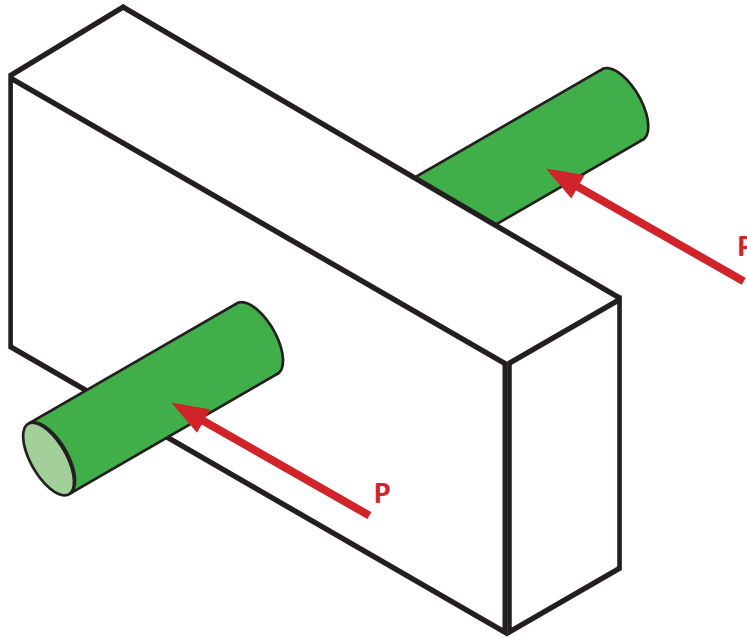

Solution.

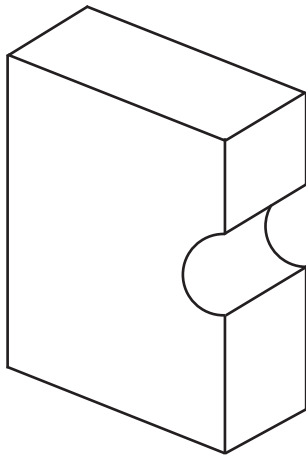

### Example

The lap joint shown is fastened by four rivets of  $\frac{3}{4}$ -in. diameter. Find the maximum load  $P$  that can be applied if the working stresses are 14 ksi for shear in the rivet and 18 ksi for bearing in the plate. Assume that the applied load is distributed evenly among the four rivets, and neglect friction between the plates.

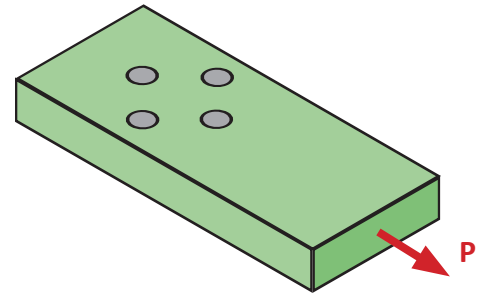
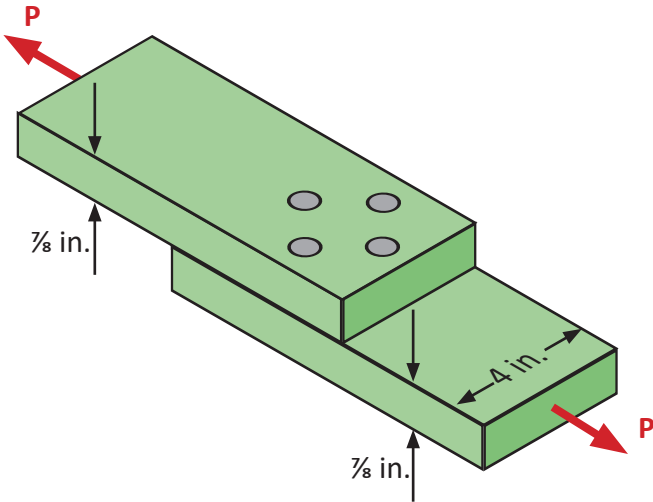

FBD - Lower Plate

Solution.

Calculate  $P$  using each of the two design criteria. The largest safe load will be the smaller of the two values.

Design for Shear Stress in Rivets

Design for Bearing Stress in Plate

### The Shaft key

Connects a gear to a shaft.

The moment  $M$  on the gear is transmitted to the shaft through the key.

The key is subjected to forces (labeled  $P$ ).

These forces are assumed to be concentrated on the rim of the shaft.

The moment  $Pr$  of  $P$  about the center of the shaft must be equal to the transmitted moment  $M$ .

$$P = \frac{M}{r}$$

The average shear stress at section m-m of the key is

$$\tau_{\text{avg}} = \frac{P}{A_s} = \frac{M/r}{bL} = \frac{M}{rbL}$$

where  $b$  is the width of the key,  $L$  is the length of the key, and  $r$  is the radius of the shaft. For a square key, the width  $b$  is approximately equal to one-quarter of the shaft diameter.

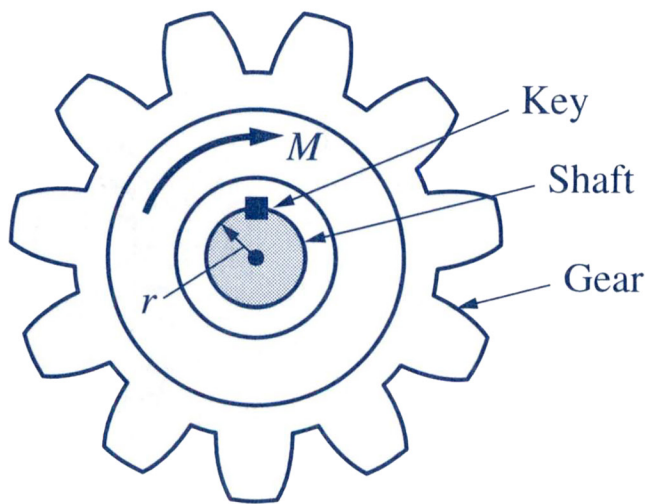

(a) Shaft key

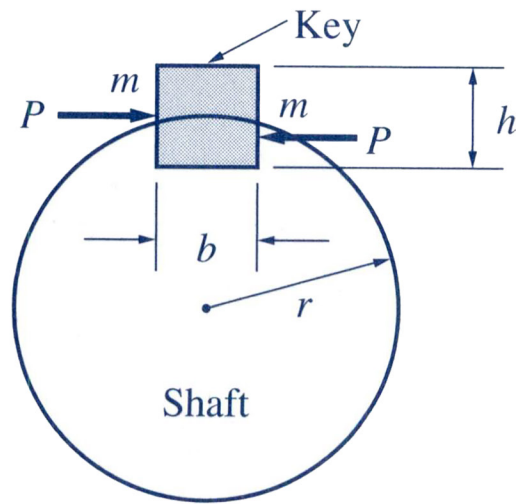

(b) Load on shaft key

### Required Shear Area

The allowable shear stress  $\tau_{\text{allow}}$  is the upper limit of shear stress that must not be exceeded.

The minimum shear area  $A_s$  required to carry a design shear load  $P$  without exceeding the allowable shear stress  $\tau_{\text{allow}}$  is

$$A_s = \frac{P}{\tau_{\text{allow}}}$$



### Bearing Stress in Shaft Key

Bearing stress occurs between the key and the gear and between the key and the shaft. The compressive force  $P$  is assumed to be uniformly distributed over an area  $(h/2)L$

The bearing stress is, therefore,

$$\sigma_b = \frac{P}{A_b} = \frac{M/r}{(h/2)L} = \frac{2M}{rhL}$$

where  $M$  = the moment transmitted by the key  
 $h$  = the height of the key  
 $L$  = the length of the key  
 $r$  = the radius of the shaft

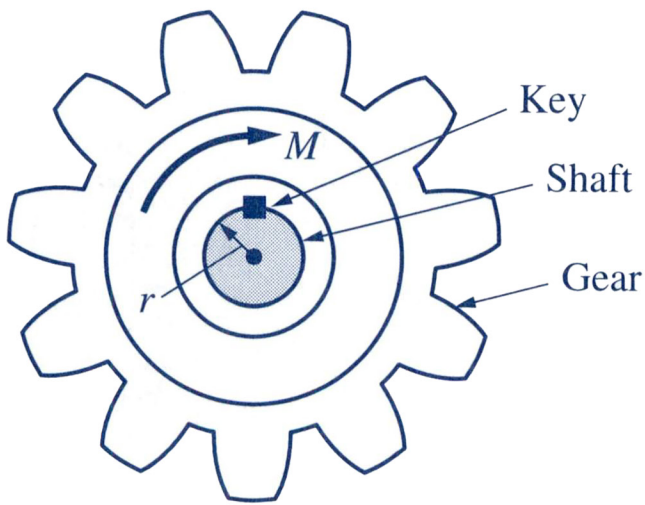

(a) Shaft key

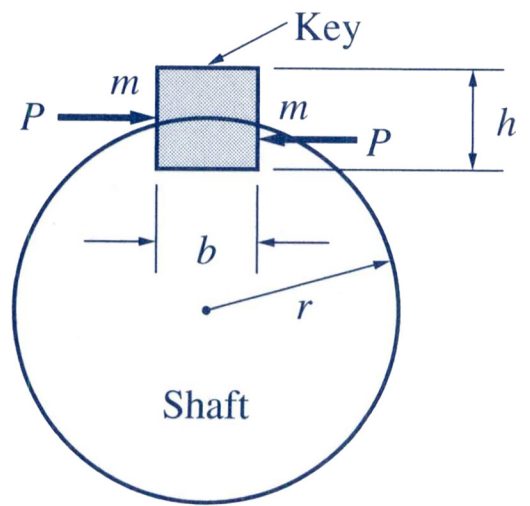

(b) Load on shaft key

### Bearing Stress Between Rivet and Plate

In the lap joint and butt joint, bearing stresses occur between rivets or bolts and the plates.

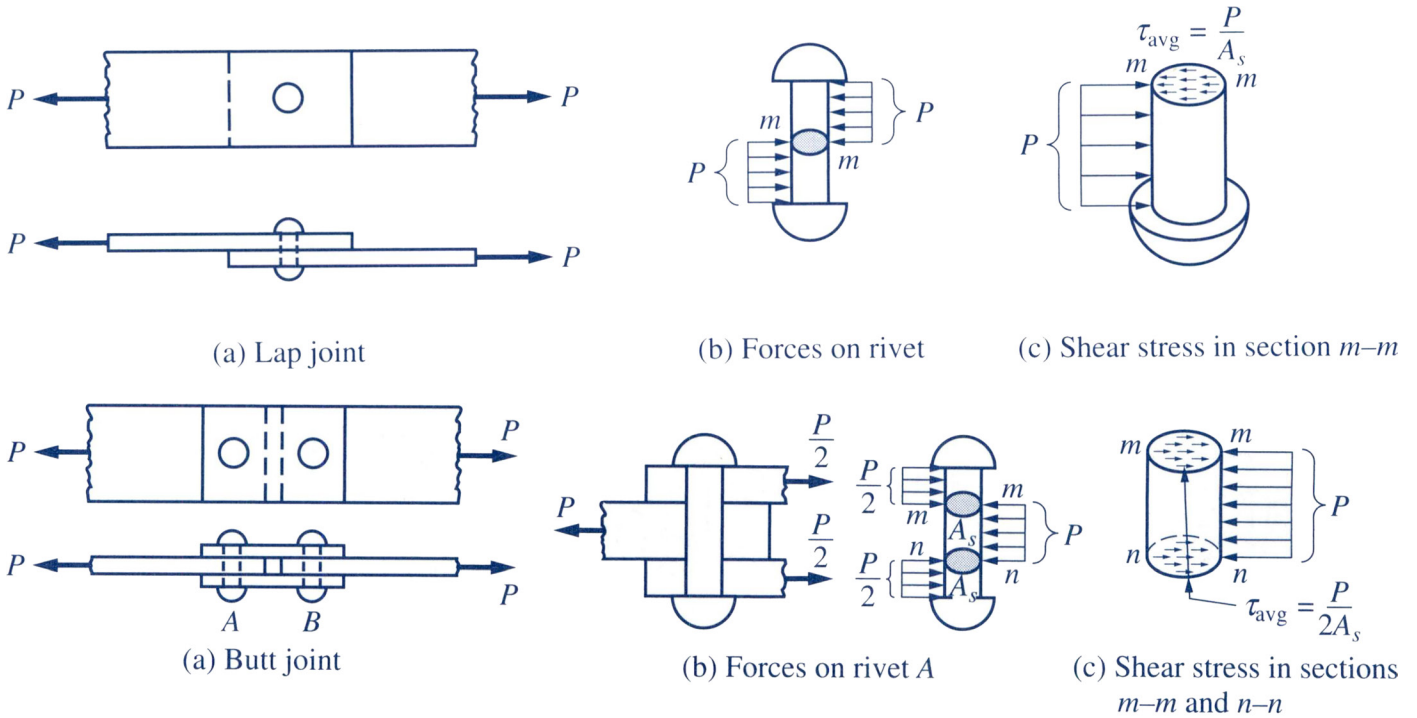

The maximum bearing stress is approximately equal to the value obtained by dividing the compressive force by the projected area of the rivet onto the plate.

The bearing stress between the rivet or the bolt and the plate is computed by

$$\sigma_b = \frac{P}{\text{projected area}} = \frac{P}{td}$$

where  $P$  = force transmitted

$t$  = thickness of the plate

$d$  = diameter of the pin

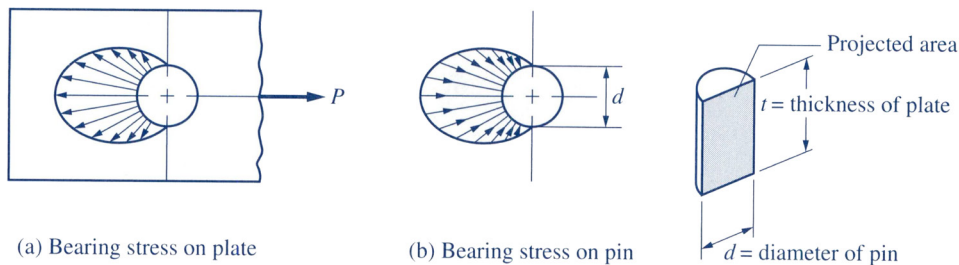

### Required Bearing Area

The allowable bearing stress  $(\sigma_b)_{\text{allow}}$  is the upper limit of compressive stress that must not be exceeded.

The minimum bearing area  $A_b$  required to carry a design bearing load without exceeding the allowable bearing stress  $(\sigma_b)_{\text{allow}}$  is

$$A_b = \frac{P}{(\sigma_b)_{\text{allow}}}$$

**Example 9-5 (textbook)**

A circular blanking punch is operated by causing shear failure in the plate. The thickness of the steel plate is 0.5-in. and the ultimate shear strength of the steel (the greatest shear stress a material can withstand before failure) is  $\tau_u = 40,000$  psi. Determine the minimum force  $P$  required to punch a hole 2-in. in diameter.

Solution.

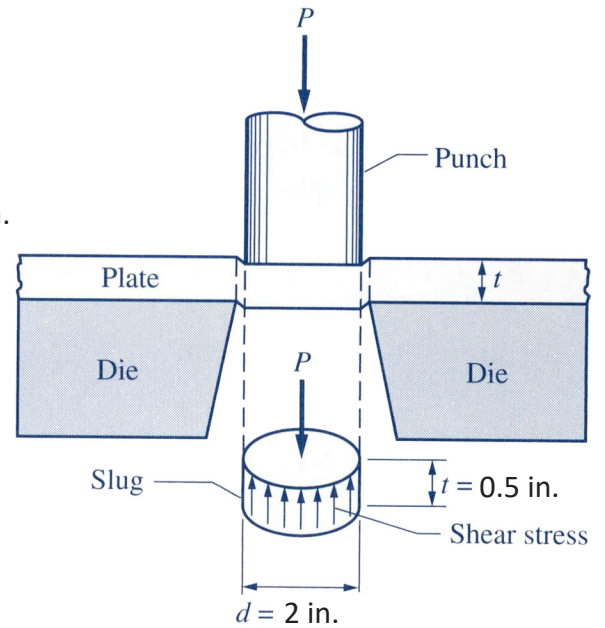

**9-16** A schematic diagram of the apparatus for determining the ultimate shear strength (failure shear stress) of wood is sketched in Fig. P9-16. The test specimen is 4 in. high, 2 in. wide, and 2 in. deep. If the load required to shear the specimen into two pieces is 8000 lb, determine the ultimate shear strength of the specimen.

Solution.

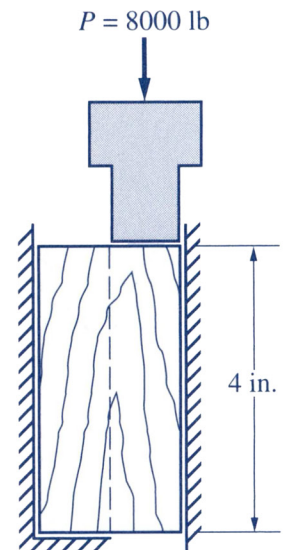

**FIGURE P9-16**

**9-18** The clevis shown is connected by a pin of  $\frac{3}{4}$  in. diameter. Determine the shear stress in the pin and the bearing stress between the pin and the plates if  $P = 10$  kips and  $t = \frac{1}{4}$  in.

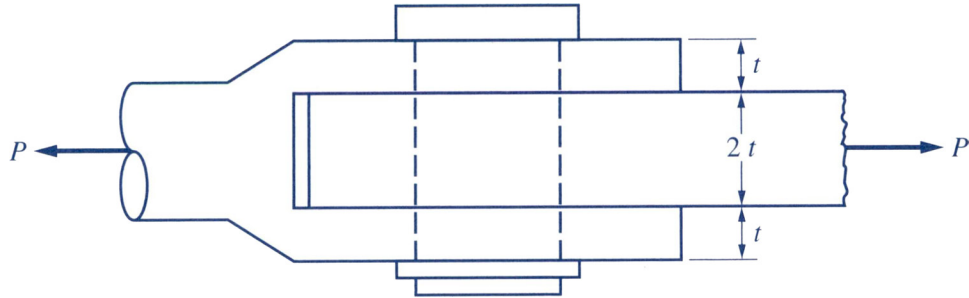

Solution.

Shear Stress in the Pin



Bearing Stress Between the Pin and the Plates

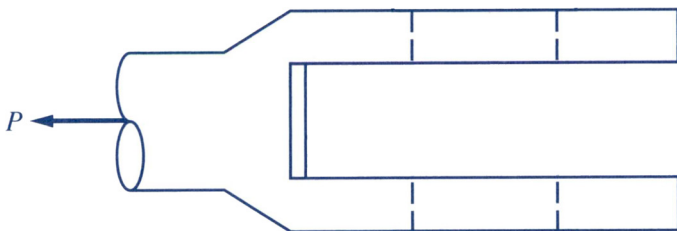

Bearing Stress Between the Pin and the Tongue



- 9-21** A force  $F = 600$  lb is applied to a crank and is transmitted to a shaft through a steel key, as shown. The key is  $\frac{1}{2}$  in. square and  $2\frac{1}{2}$  in. long. Determine (a) the shear stress in the key and (b) the bearing stress between the key and the shaft.

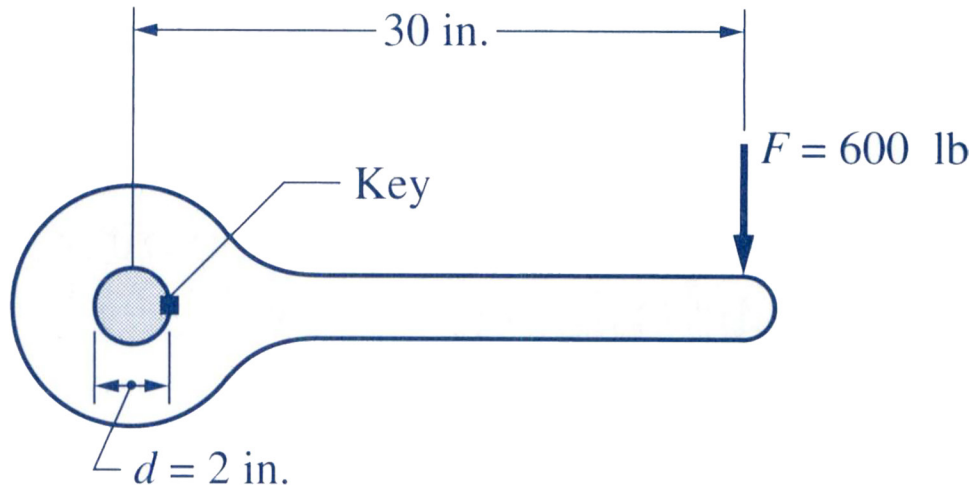

Solution.

(a) Shear Stress in the Key

(b) Bearing Stress between the Key and the Shaft



### Example - Single Shear Stress

Consider a 1 in diameter rod passing through the two connections as shown. Force P is applied to each connection equal and opposite in direction. If P = 20 lb determine the shear stress in the rod.

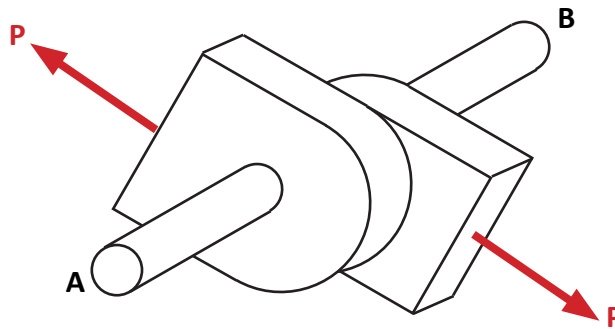

Sketch the free-body diagram of the top view of the rod.

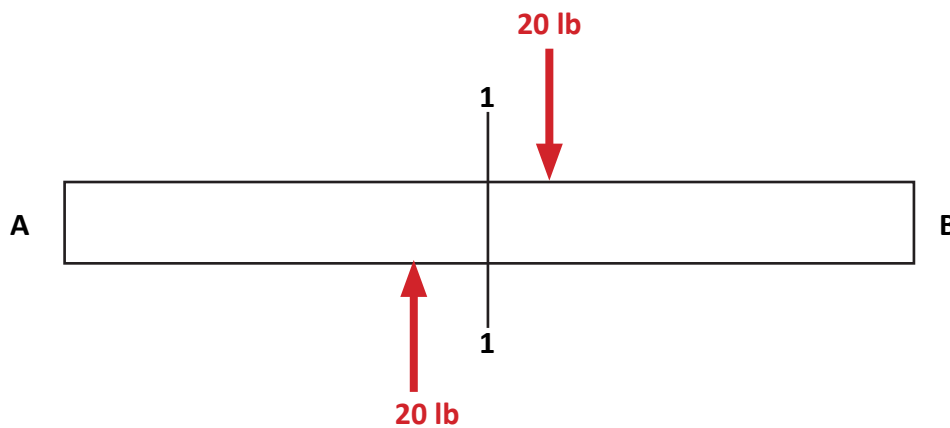

Free-Body Diagram — Top View of the Rod

Cut through the rod at section 1-1 and sketch the free-body diagram of the left portion of section 1-1

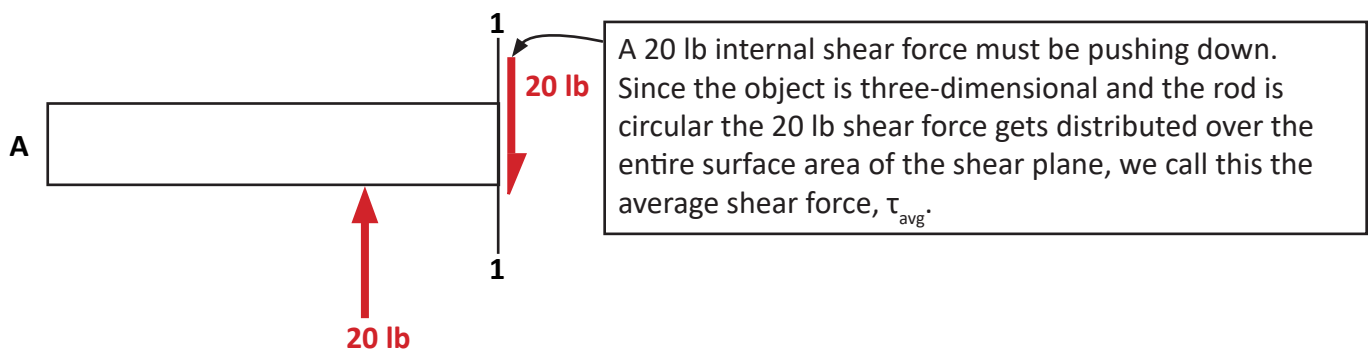

Free-Body diagram of the left portion of section 1-1

### Example - Double Shear Stress

Consider the same part as previously discussed, but add a third plate as shown. If  $P$  is applied to the middle connection by equilibrium the force in the other connections must be in the opposite direction and each force is equal to  $P/2$ . If  $P = 20$  lb determine the shear stress in the rod.

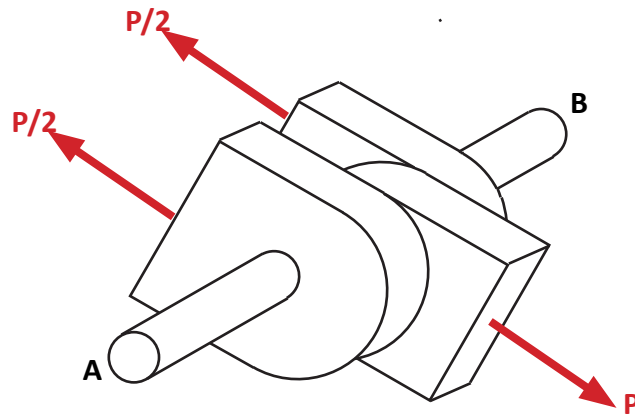

Sketch the free-body diagram of the top view of the rod.

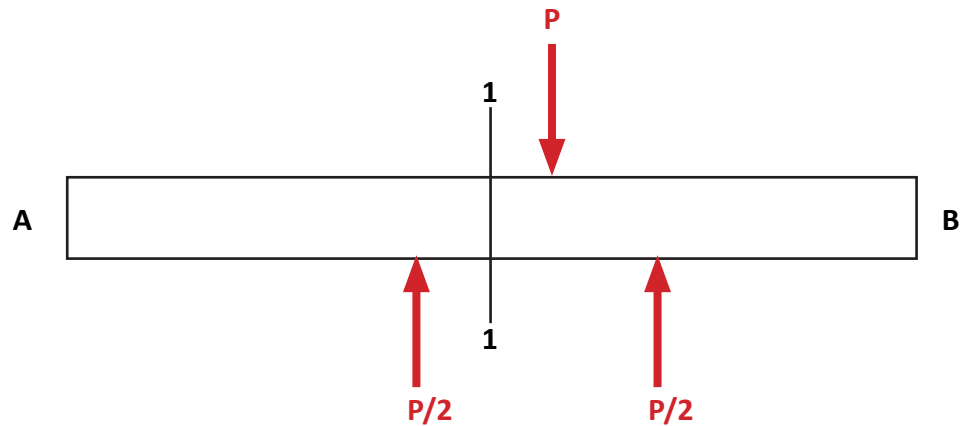

Free-Body Diagram — Top View of the Rod

Cut through the rod at section 1-1 and sketch the free-body diagram of the left portion of section 1-1

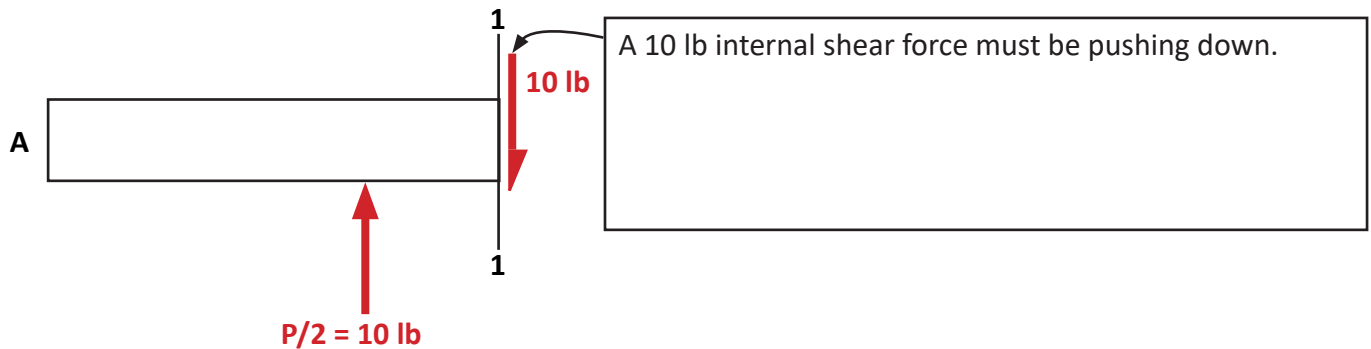

Free-Body diagram of the left portion of section 1-1